

Si-Steel Transformers

EI Series (Lead Wire)

Mechanical Dimension : Unit : mm

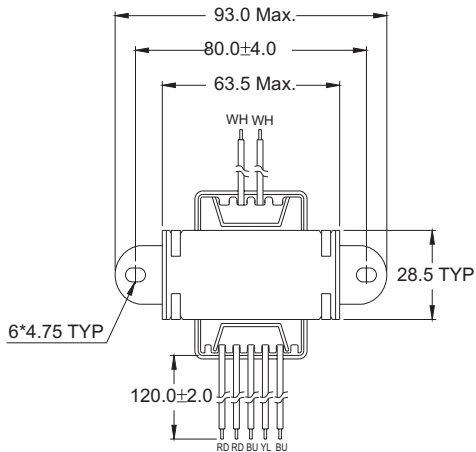
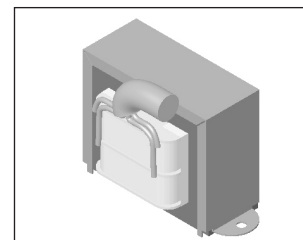
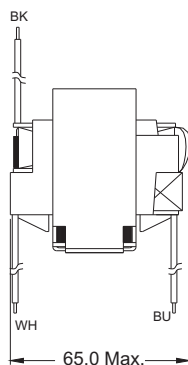
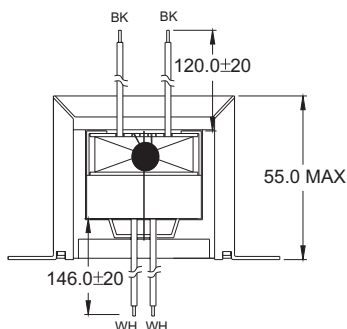

Schematic:

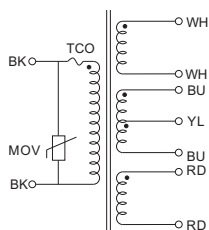

Used on :

- Air conditioner
- Refrigerator & freezer
- Heat Pump
- Washer
- Dishwasher
- Auto Industrial control
- For UPS

Electrical Characteristics :

■ Ambient Temperature at 25°C

PART NO.	INPUT VOLTAGE(Vac)	OUTPUT VOLTAGE(Vac)						DCR(Ω) Max.				POWER(W)	EXCITING CURRENT (mA)Max.	TEMPERATURE RISE(°C) Max.
		Load			No Load			BK-BK	WH-WH	BU-BU	RD-RD			
		WH-WH	BU-BU	RD-RD	WH-WH	BU-BU	RD-RD							
SEL5725V	120,60Hz	20.5@0.6A	4.5@0.6A	26.0@0.1A	23.0	5.0	27.0	30.0	2.0	0.6	12.0	20	50	65



DELTA ELECTRONICS, INC.

(TAOYUAN PLANT CPBG) 252, SAN YING ROAD, KUEISAN INDUSTRIAL ZONE, TAOYUAN SHIEN, 333, TAIWAN, R.O.C.

TEL: 886-3-3591968; FAX: 886-3-3591991

<http://www.deltawww.com>